

# Modbus Server

## Hitachi VRF Air Conditioning

Gateway for the integration of Hitachi VRF systems into Modbus (RTU and TCP) systems

### USER MANUAL

Issue date: 11/2018 r1.0 ENGLISH

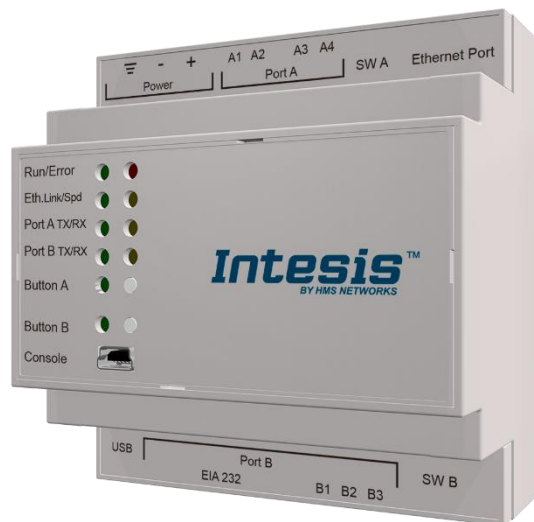

## Important User Information

### Disclaimer

The information in this document is for informational purposes only. Please inform HMS Industrial Networks of any inaccuracies or omissions found in this document. HMS Industrial Networks disclaims any responsibility or liability for any errors that may appear in this document.

HMS Industrial Networks reserves the right to modify its products in line with its policy of continuous product development. The information in this document shall therefore not be construed as a commitment on the part of HMS Industrial Networks and is subject to change without notice. HMS Industrial Networks makes no commitment to update or keep current the information in this document.

The data, examples and illustrations found in this document are included for illustrative purposes and are only intended to help improve understanding of the functionality and handling of the product. In view of the wide range of possible applications of the product, and because of the many variables and requirements associated with any particular implementation, HMS Industrial Networks cannot assume responsibility or liability for actual use based on the data, examples or illustrations included in this document nor for any damages incurred during installation of the product. Those responsible for the use of the product must acquire sufficient knowledge in order to ensure that the product is used correctly in their specific application and that the application meets all performance and safety requirements including any applicable laws, regulations, codes and standards. Further, HMS Industrial Networks will under no circumstances assume liability or responsibility for any problems that may arise as a result from the use of undocumented features or functional side effects found outside the documented scope of the product. The effects caused by any direct or indirect use of such aspects of the product are undefined and may include e.g. compatibility issues and stability issues.

Gateway for the integration of Hitachi VRF systems into Modbus (RTU and TCP) systems.

<b>ORDER CODE</b>	<b>LEGACY ORDER CODE</b>
INMBSHIT016O000	HI-AC-MBS-16
INMBSHIT064O000	HI-AC-MBS-64

## INDEX

1. Description.....	5
1.1 Introduction.....	5
1.1 Functionality.....	6
1.2 Capacity of Intesis.....	7
2. Modbus interface.....	8
1.3 Functions supported.....	8
1.4 Modbus RTU.....	8
1.5 Modbus TCP.....	8
1.6 Modbus Address Map.....	9
3. Connections.....	12
1.7 Power device.....	13
1.8 Connect to Hitachi VRF installation.....	13
1.9 Connection to Modbus.....	13
1.9.1 Modbus TCP.....	13
1.9.2 Modbus RTU.....	13
1.10 Connection to PC (Configuration tool).....	14
4. Set-up process and troubleshooting.....	15
1.11 Pre-requisites.....	15
1.12 Intesis MAPS. Configuration & monitoring tool for Intesis Modbus series.....	15
1.12.1 Introduction.....	15
1.12.2 Connection.....	15
1.12.3 Configuration tab.....	16
1.12.4 Modbus Slave configuration.....	16
1.12.5 Hitachi configuration.....	18
1.12.6 Signals.....	20
1.12.7 Sending the configuration to Intesis.....	21
1.12.8 Diagnostic.....	21
1.12.9 Set-up procedure.....	22
5. Electrical & Mechanical Features.....	24
6. Dimensions.....	25
7. AC Unit Types compatibility.....	26
8. Error codes for Indoor and Outdoor Units.....	27

## 1. Description

### 1.1 Introduction

This document describes the integration of Hitachi VRF air conditioning systems into Modbus compatible devices and systems using using gateway the Intesis Modbus Server to *Hitachi VRF* communication gateway.

The aim of this integration is to monitor and control Hitachi air conditioning systems, remotely, from a Control Center using any commercial SCADA or monitoring software that includes a Modbus Master driver (RTU and/or TCP). To do it so, Intesis performs as a Modbus Server, allowing poll and write requests from any Modbus master device.

Intesis makes available the Hitachi air conditioning system indoor units' datapoints through independent Modbus registers.

Up to 64 indoor units supported, depending on product version.

This document assumes that the user is familiar with Modbus and Hitachi technologies and their technical terms.

HITACHI

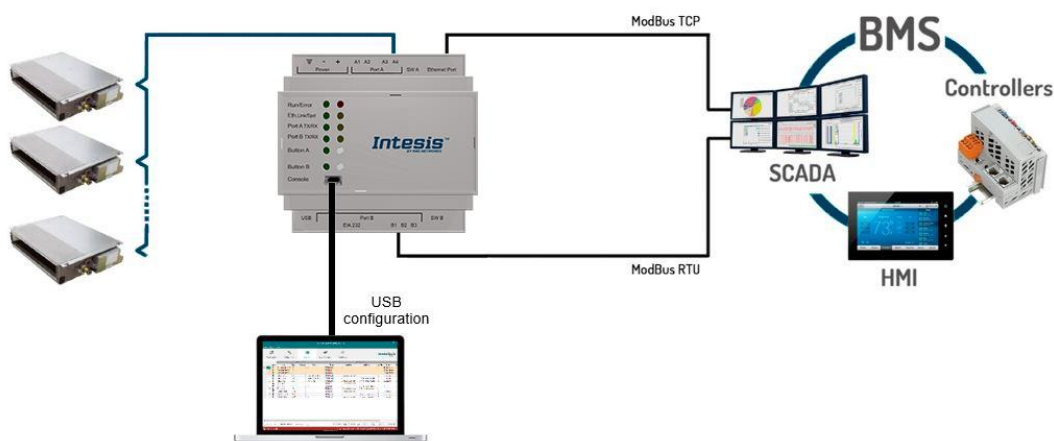

Integration of Hitachi's compatible systems into Modbus systems

## 1.1 Functionality

Intesis™ continuously monitors Hitachi VRF network for all configured signals and keeps the updated status of all of them in its memory, ready to be served when requested from the Modbus master.

Commands toward the indoor units are permitted.

Each indoor unit is offered as a set of MBS objects.

Element	Object supported
Outdoor Unit	<ul style="list-style-type: none"><li>• Status</li></ul>
Indoor Unit	<ul style="list-style-type: none"><li>• Status</li><li>• Command</li><li>• Communication status</li></ul>
General signals (all units)	<ul style="list-style-type: none"><li>• Command</li></ul>

## 1.2 Capacity of Intesis

Element	Max.	Notes
Number of indoor units	64 *	Number of indoor units that can be controlled through Intesis

\* There are different models of *Intesis MBS – Hitachi VRF* each one with different capacity. The table above shows the capacity for the top model (with maximum capacity).

Their order codes are:

- INMBSHIT016O000: Model supporting up to 16 indoor units
- INMBSHIT064O000: Model supporting up to 64 indoor units

## 2. Modbus interface

In this section, a common description for all Intesis Modbus series gateways is given, from the point of view of Modbus system which is called from now on *internal system*. Connection with the Hitachi VRF system is also called from now on *external system*.

### 1.3 Functions supported

This part is common for Modbus RTU and TCP.

Modbus functions 03 and 04 (*Read Holding Registers* and *Read Input Registers*) can be used to read Modbus registers.

Modbus functions 06 and 16 (*Single Multiple Holding Registers* and *Write Multiple Holding Registers*) can be used to write Modbus registers.

Configuration of poll records is possible between Modbus addresses 0 and 20000. Addresses that are not defined in section 2.2 (Modbus map of the device) are read-only and will always report 0.

Modbus error codes are supported, they will be sent whenever a non-valid Modbus address is queried.

All registers are 16-bit signed integer, in standard Modbus Big Endian (MSB/LSB) format.

Intesis supports Modbus RTU and Modbus TCP and both interfaces can be used simultaneously.

### 1.4 Modbus RTU

Both EIA485 and EIA232 physical layers are supported. Only the lines RX, TX and GND of the EIA232 connector are used (TX and RX for EIA485).

Baud rate can be selected between 1200, 2400, 4800, 9600, 19200, 38400, 56700 and 115200. Parity (none, even or odd) and stop bits (1 or 2) can be selected as well.

Modbus slave number must be configured and the physical connection (RS232 or RS485) can also be selected

### 1.5 Modbus TCP

TCP port to use (default is 502) and keep alive period must be configured.

IP settings of Intesis (DHCP status, own IP, net mask and default gateway) must be configured as well.



## 1.6 Modbus Address Map

Modbus address from the formula is expressed in link layer format. This is, first register address is 0.

Modbus Address First Address is 0	Read /Write	Register/signal name	Possible values
0	W	On (all the units)	1-Set all the units On
1	W	Off (all the units)	1-Set all the units Off
2	W	Operation Mode Auto (all the units)	1-Set Auto Mode
3	W	Operation Mode Heat (all the units)	1-Set Heat Mode
4	W	Operation Mode Dry (all the units)	1-Set Dry Mode
5	W	Operation Mode Fan (all the units)	1-Set Fan Mode
6	W	Operation Mode Cool (all the units)	1-Set Cool Mode
7	W	Fan Speed Auto (all the units)	1-Set Fan Speed Auto
8	W	Fan Speed Low (all the units)	1-Set Fan Speed Low
9	W	Fan Speed Mid (all the units)	1-Set Fan Speed Mid
10	W	Fan Speed High (all the units)	1-Set Fan Speed High
11	W	Fan Speed High+ (all the units)	1-Set Fan Speed High+
12	W	Vane Position Auto (all the units)	1-Set Vane Position Auto
13	W	Vane Position 1 (all the units)	1-Set Vane Position 1
14	W	Vane Position 2 (all the units)	1-Set Vane Position 2
15	W	Vane Position 3 (all the units)	1-Set Vane Position 3
16	W	Vane Position 4 (all the units)	1-Set Vane Position 4
17	W	Vane Position 5 (all the units)	1-Set Vane Position 5
18	W	Vane Position 6 (all the units)	1-Set Vane Position 6
19	W	Vane Position 7 (all the units)	1-Set Vane Position 7

20	W	Temperature Setpoint (x10°C) (all units)	Cool: 19..30°C; Heat: 17..30°C
(OU*25)+10000+0 OU stands for Outdoor Unit address from 1 to 64.	R	Communication Error OU	0-No error, 1-Error
(OU*25)+10000+1	R	Outdoor Air Temp.	-50..99 °C
(OU*25)+10000+2	R	Comp.Top Temp.	0..200 °C
(OU*25)+10000+3	R	Total Real Comp. Freq.	0..255 Hz
(OU*25)+10000+4	R	Total Comp. Current	0..255 A
(OU*25)+10000+5	R	Out Exp. Valve 1 Open	0..100 %
(OU*25)+10000+6	R	Discharge Pressure (x10°C)	-5.0..9.9 MPa
(OU*25)+10000+7	R	Suction Pressure (x10°C)	-5.0..9.9 MPa
(Ui*100)+0 Ui stands for Unit index number as found in the Units Configuration tab and ranges from 1 to 64.	R/W	On/Off	0-Off, 1-On
(Ui*100)+1	R/W	Operation Mode	0-Auto, 1-Heat, 2-Dry, 3-Fan, 4-Cool
(Ui*100)+2	R/W	Fan Speed	0-Auto, 1-Low, 2-Mid, 3-High, 3-High+
(Ui*100)+3	R/W	Vane Position	0-Auto, 1-Pos1..7-Pos7
(Ui*100)+4	R/W	Temperature Setpoint (x10°C)	Cool:19..30°C; Heat:17..30°C
(Ui*100)+5	R	Remote Sensor Temp. (x10°C)	-63..63°C
(Ui*100)+6	R	Inlet Temp. (x10°C)	-63..63°C
(Ui*100)+7	R	Outlet Temp. (x10°C)	-63..63°C
(Ui*100)+8	R	GasPipe Temp. (x10°C)	-63..63°C
(Ui*100)+9	R	LiquidPipe Temp. (x10°C)	-63..63°C
(Ui*100)+10	R	Unit Error code	Error code
(Ui*100)+11	R	Filter Alarm	0-Normal, 1-Alarm
(Ui*100)+12	W	Filter Alarm Reset	1-Reset
(Ui*100)+13	R	Communication Status	0-Not Exit, 1-Exist

(Ui*100)+14	R/W	Allow On/Off from RC	0-Allow, 1-Not allow
(Ui*100)+15	R/W	Allow Mode from RC	0-Allow, 1-Not allow
(Ui*100)+16	R/W	Allow Setpoint from RC	0-Allow, 1-Not allow
(Ui*100)+17	R/W	Allow Fan from RC	0-Allow, 1-Not allow
(Ui*100)+18	R	Unit Type	0:Not Defined,1-SS,2-FC,3-VRF,4-IU,5-ES
(Ui*100)+19	R	Unit Address	1..64
(Ui*100)+20	R	System Address	1..64
(Ui*100)+21	R	Dehumidification	0-Disabled, 1-Enabled
(Ui*100)+22	R/W	Dehumidification Correction	0-0, 1-(-1), 2-(-2)
(Ui*100)+23	R	Compressor Stop Cause	255-Operation Off, Other-See manual
(Ui*100)+24	R	Expansion Valve Open	0..100%
(Ui*100)+25	R	Operation Condition	0-Off, 1-Thermo Off, 2-Thermo On, 3-Alarm
(Ui*100)+26	R	RC SW Temperature (x10°C)	-63..63°C
(Ui*100)+27	R	RC SW Config	0-Without RCS, 1-With RCS

### 3. Connections

Find below information regarding the Intesis connections available.

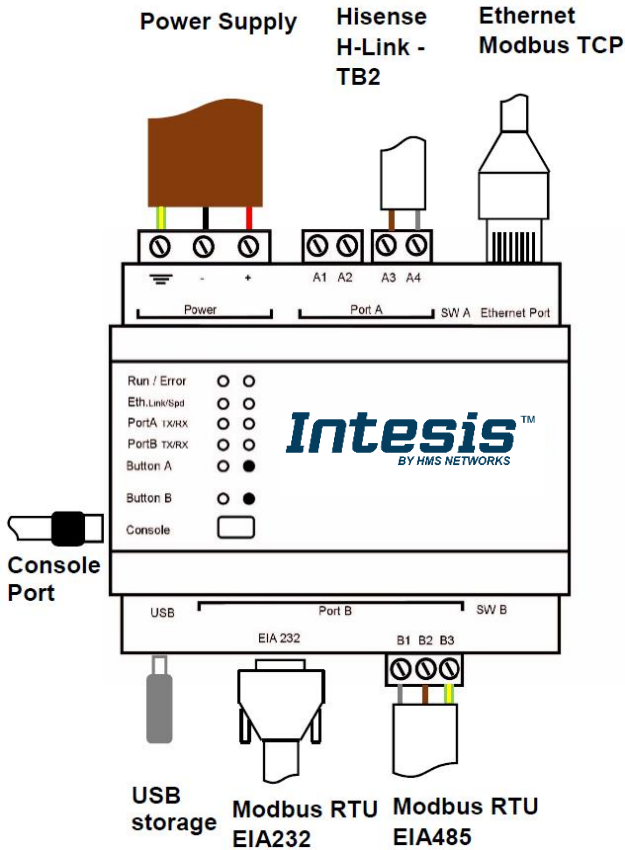

**Power Supply**

Must use NEC Class 2 or Limited Power Source (LPS) and SELV rated power supply.

**If using DC power supply:**

Respect polarity applied of terminals (+) and (-). Be sure the voltage applied is within the range admitted (check table below). The power supply can be connected to earth but only through the negative terminal, never through the positive terminal.

**If using AC power supply:**

Make sure the voltage applied is of the value admitted (24 Vac). Do not connect any of the terminals of the AC power supply to earth, and make sure the same power supply is not supplying any other device.

**Ethernet / Modbus TCP (TCP) / Console (UDP & TCP)**

Connect the cable coming from the IP network to the connector ETH of the gateway. Use an Ethernet CAT5 cable. If communicating through the LAN of the building, contact the network administrator and make sure traffic on the port used is allowed through all the LAN path (check the gateway user manual for more information). Default IP is 192.168.100.246. DHCP is enabled by default.

**PortA / H-Link Hitachi**

Connect the H-Link terminals (TB2) of Hitachi Outdoor Unit to the connectors A3 and A4 of gateway's PortA. There is no polarity to be respected.

**PortB / Modbus-RTU RS485**

Connect the EIA485 bus to connectors B1 (B+), B2 (A-) and B3 (SNGD) of gateway's PortB. Respect the polarity. Remember the characteristics of the standard EIA485 bus: maximum distance of 1200 meters, maximum 32 devices connected to the bus, and in each end of the bus it must be a termination resistor of 120 Ω. Bus biasing and termination resistor for EIA485 can be enabled for PortB by means of a dedicated DIP:

SW1:

- ON:** 120 Ω termination active
- OFF:** 120 Ω termination inactive (Default setting).

SW2+3:

- ON:** Polarization active
- OFF:** Polarization inactive (Default setting).

If the gateway is installed in one bus end, make sure that termination is active.

**Console Port**

Connect a mini-type B USB cable from your computer to the gateway to allow communication between the Configuration Software and the gateway. Remember that Ethernet connection is also allowed. Check the user manual for more information.

**USB**

Connect a USB storage device (not a HDD) if required. Check the user manual for more information.

Ensure proper space for all connectors when mounted (see section 6).

## 1.7 Power device

The first step to perform is to power up the device. To do so, a power supply working with any of the voltage range allowed is needed (check section 5). Once connected the ON led will turn on.

**WARNING!** In order to avoid earth loops that can damage the gateway, and/or any other equipment connected to it, we strongly recommend:

- The use of DC power supplies, floating or with the negative terminal connected to earth. **Never use a DC power supply with the positive terminal connected to earth.**
- The use of AC power supplies only if they are floating and not powering any other device.

## 1.8 Connect to Hitachi VRF installation

Use the PortA connector in the top corner of the Intesis device in order to connect H-Link bus to the Intesis. Remember to follow all safety precautions indicated by Hitachi.

Connect the Hitachi H-Link/TB2 bus to connectors A3 and A4 of gateway's PortA. Bus is not sensitive to polarity.

## 1.9 Connection to Modbus

### 1.9.1 Modbus TCP

The gateway's Ethernet port connection is used for Modbus TCP communication. Connect the communication cable coming from the network hub or switch to the Ethernet port of Intesis. The cable to be used shall be a straight Ethernet UTP/FTP CAT5 cable.

TCP port to use (default 502) and keep alive period must be configured.

IP settings of the gateway (DHCP status, own IP, netmask and default gateway) must be configured as well.

### 1.9.2 Modbus RTU

Connect the communication cable coming from the modbus network to the port marked as Port B of the Intesis. Connect the EIA485 bus to connectors B1 (-), B2 (+) and B3 (SNGD) of gateway's PortB. Respect the polarity.

Remember the characteristics of the standard EIA485 bus: maximum distance of 1200 meters, maximum 32 devices (without repeaters) connected to the bus, and in each end of the bus it must be a termination resistor of 120 Ω. The gateway has an internal bus biasing circuit that incorporates the termination resistor. Bus biasing and termination resistor for EIA485 can be enabled for PortB by means of a dedicated DIP switch.

## 1.10 Connection to PC (Configuration tool)

This action allows the user to have access to configuration and monitoring of the device (more information can be found in the configuration tool User Manual). Two methods to connect to the PC can be used:

- **Ethernet:** Using the Ethernet port of Intesis.
- **USB:** Using the console port of Intesis, connect a USB cable from the console port to the PC.

## 4. Set-up process and troubleshooting

### 1.11 Pre-requisites

It is necessary to have the Modbus RTU or TCP master/client device (BMS side device) operative and properly connected to the corresponding port of the gateway and the Hitachi VRF installation connected to their corresponding ports as well.

Connectors, connection cables, PC for the Configuration Tool usage and other auxiliary material, if needed, are not supplied by Intesis for this standard integration.

Items supplied by HMS Networks for this integration are:

- Intesis gateway.
- Link to download the configuration tool.
- USB Console cable to communicate with Intesis.
- Product documentation.

### 1.12 Intesis MAPS. Configuration & monitoring tool for Intesis Modbus series

#### 1.12.1 Introduction

Intesis MAPS is a Windows® compatible software developed specifically to monitor and configure Intesis new generation gateways.

The installation procedure and main functions are explained in the *Intesis MAPS User Manual*. This document can be downloaded from the link indicated in the installation sheet supplied with the Intesis device or in the product website at [www.intesis.com](http://www.intesis.com)

In this section, only the specific case of Hitachi VRF to Modbus systems will be covered.

Please check the Intesis MAPS User Manual for specific information about the different parameters and how to configure them.

#### 1.12.2 Connection

To configure the Intesis connection parameters press on the **Connection** button in the *menu bar*.

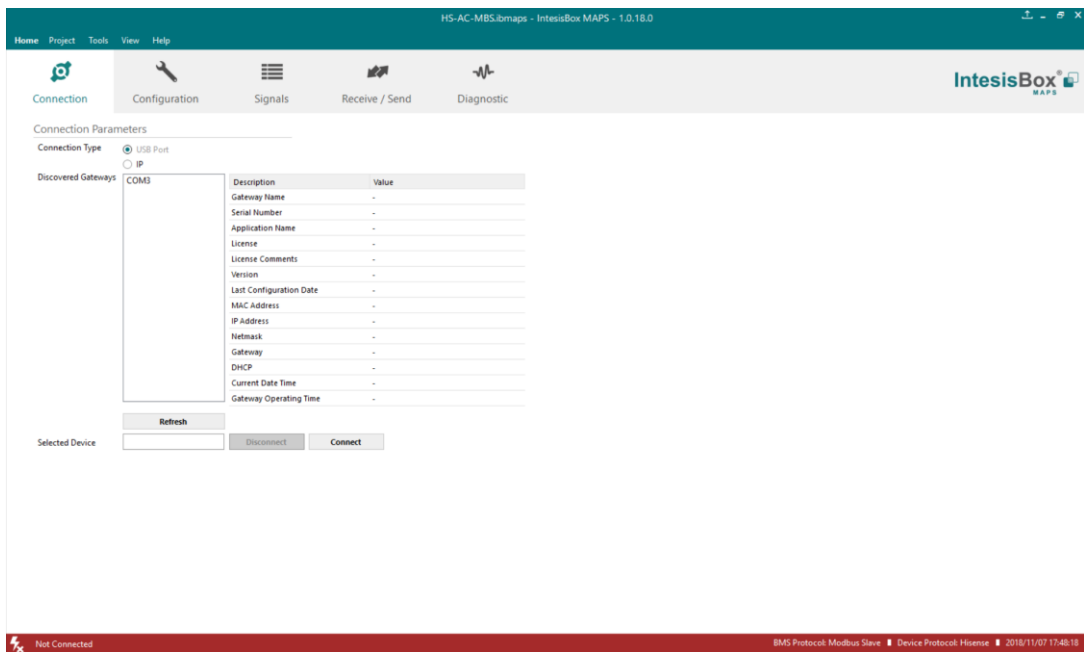

Figure 4.1 MAPS connection

### 1.12.3 Configuration tab

Select the **Configuration** tab to configure the connection parameters. Three subsets of information are shown in this window: General (Gateway general parameters), Modbus Slave (Modbus interface configuration) and Hitachi (Hitachi interface parameters).

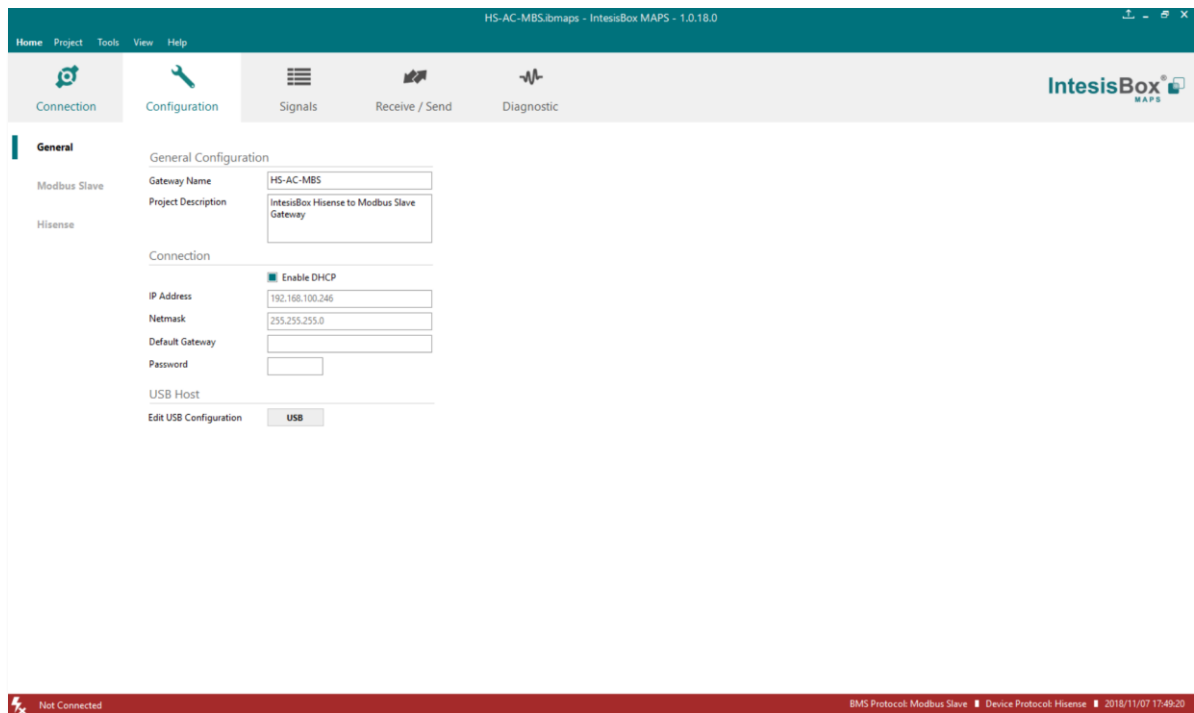

Figure 4.2 Intesis MAPS configuration tab

### 1.12.4 Modbus Slave configuration

Set parameters of Modbus Slave interface of Intesis.



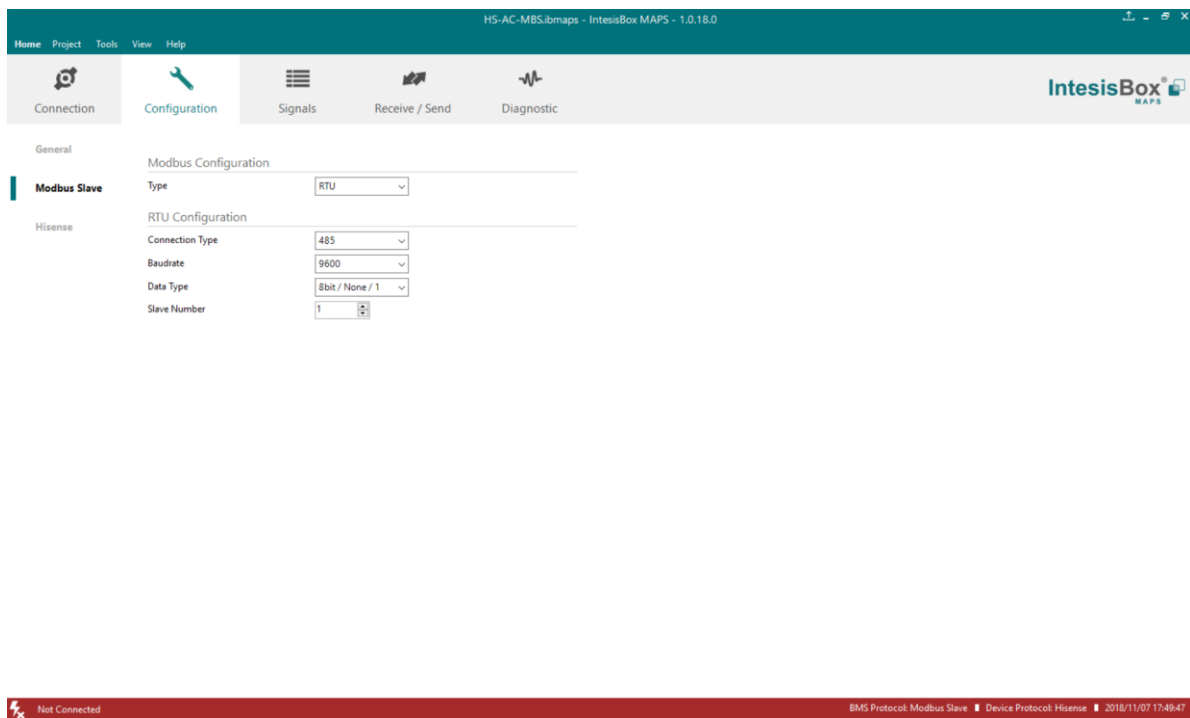

Figure 4.3 Intesis MAPS Modbus configuration tab

## 1. Modbus Configuration

**1.1. Modbus type selection.** Select RTU, TCP or simultaneous RTU and TCP communication.

## 2. TCP Configuration.

**2.1. Modbus TCP Port:** Modbus TCP communication port setting. Default port 502.

**2.2. Keep Alive.** Set the time of inactivity to send a keep Alive message. Default 10 minutes.

## 3. RTU Configuration.

**3.1. RTU bus connection type.** Select the RTU connection type serial bus RS485 or 232.

**3.2 Baudrate.** Set the RTU bus communication speed. Default: 9600 bps.

- Available values: 1200, 2400, 4800, 9600, 19200, 38400, 57600, 115200 bps.

**3.3 Data Type.** Set the Data-bit/parity/stop-bit. Default: 8bit/None/1.

- Available selection: 8bit/None/1, 8bit/Even/1, 8bit/Odd/1, 8bit/None/2.

**3.4 Slave Number.** Set the Modbus Slave address. Default slave address: 1.

- Valid address: 1..255.

## 1.12.5 Hitachi configuration

Set parameters for connection with Hitachi's installation.

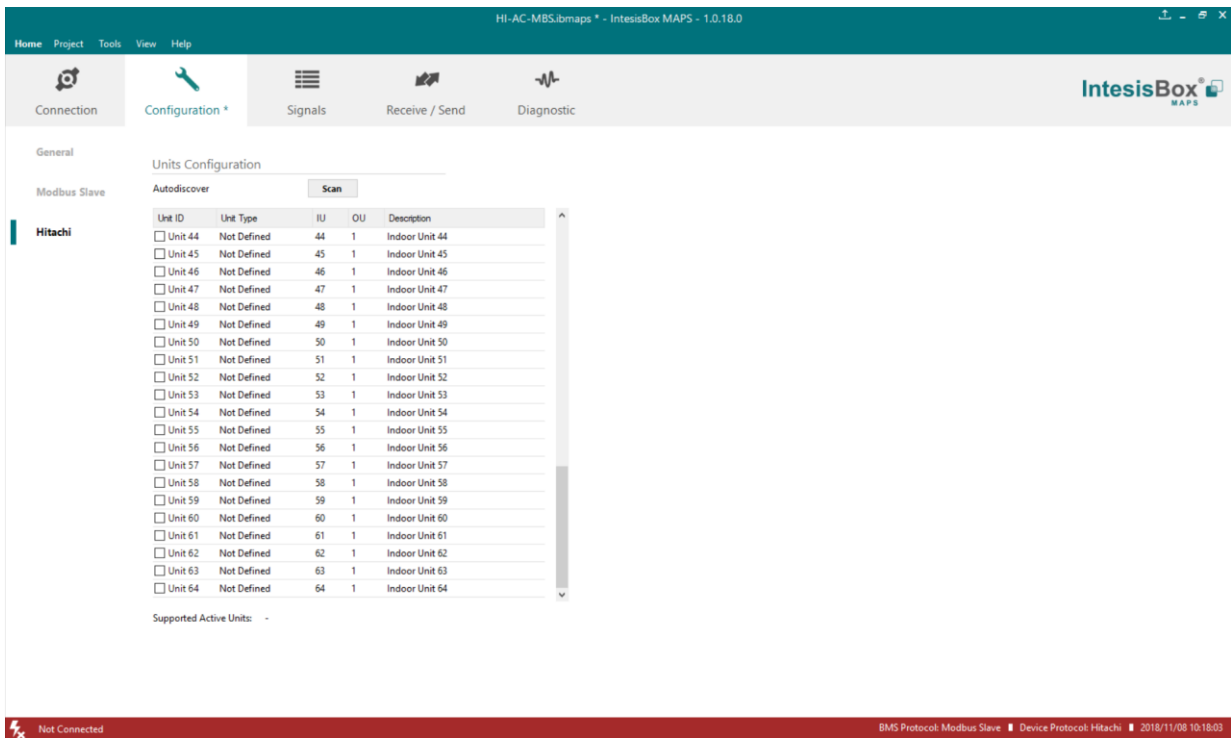

**Figure 4.4** Intesis MAPS Hitachi configuration tab

In Units Configuration section you need to enter, for each unit:

- **Active.** If it's active (checkbox at Unit xx), ranging from 1 to 64 indoor units that will be integrated (maximum number of units will depend on Intesis model)
- **IU address.** Address 1..64 of Unit in Hitachi H-Link bus.
- **OU address.** Address 1..64 of Outdoor Unit in Hitachi H-Link bus.
- **Description.** Descriptive name to easy identification of the unit (for example, 'living room floor 1 unit', etc).

Additional to manual entry of each unit, autodiscover of present units in an H-Link installation is possible. To do so, click button **Scan**. Following window will appear:

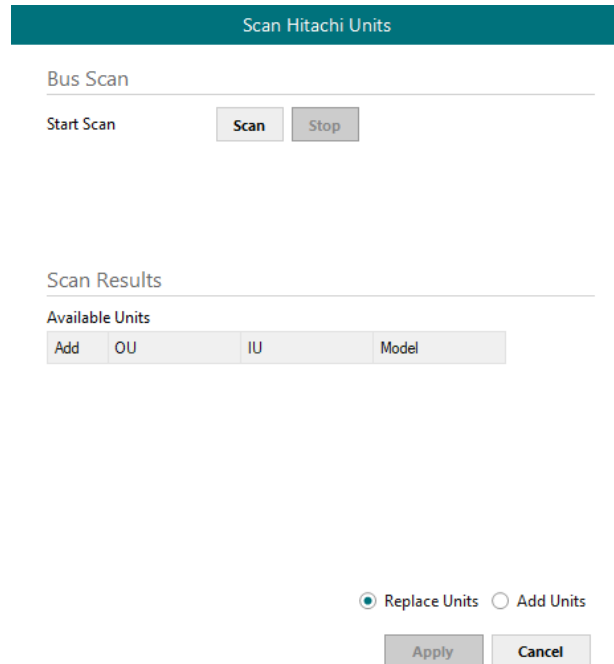

Figure 4.5 Intesis MAPS Scan Hitachi Units window

By pressing **Scan** button, connected Hitachi H-Link bus will be scanned for available units. Error window will appear if there is a problem in the connection with H-Link bus (units not powered, bus not connected, ...).

A progress bar will appear during the scan, which will take up to a few minutes. After scan is completed, detected units will be shown in available units as follows:

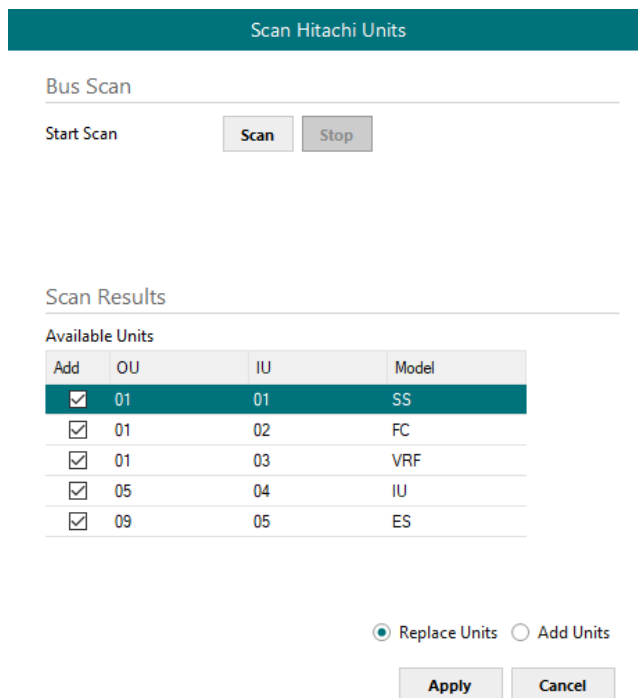

Figure 4.6 Intesis MAPS Scan Hitachi Units window with scan results

Select with its checkbox units to add (or replace) in installation, according to selection **Replace Units** / **Add Units**. After units to be integrated are selected, click button **Apply**, and changes will appear in previous **Units Configuration** window.

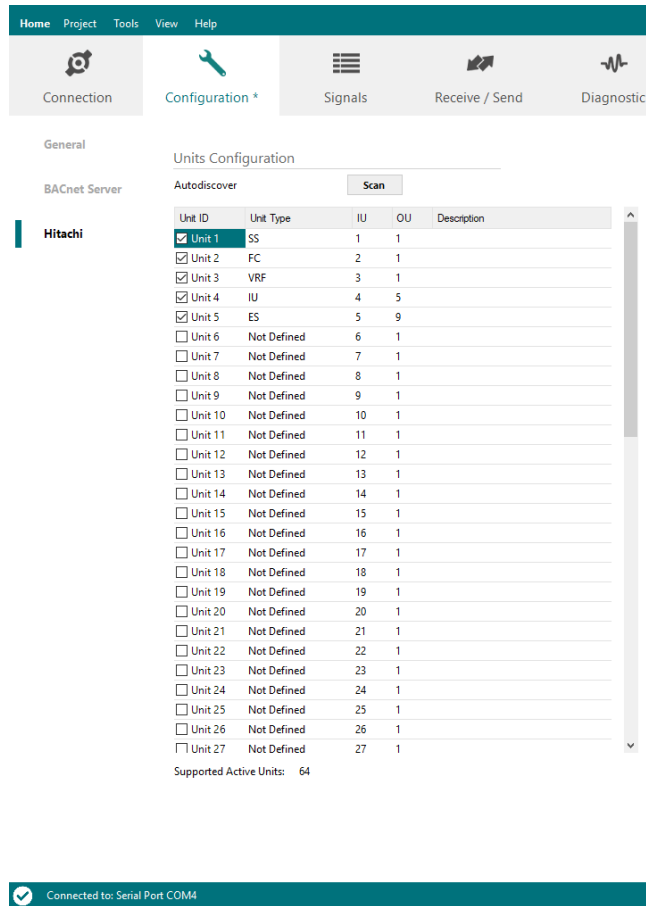

Figure 4.7 Intesis MAPS Hitachi configuration tab after importing scan results

### 1.12.6 Signals

All available Modbus registers, its corresponding description and other main parameters are listed in the signals tab.

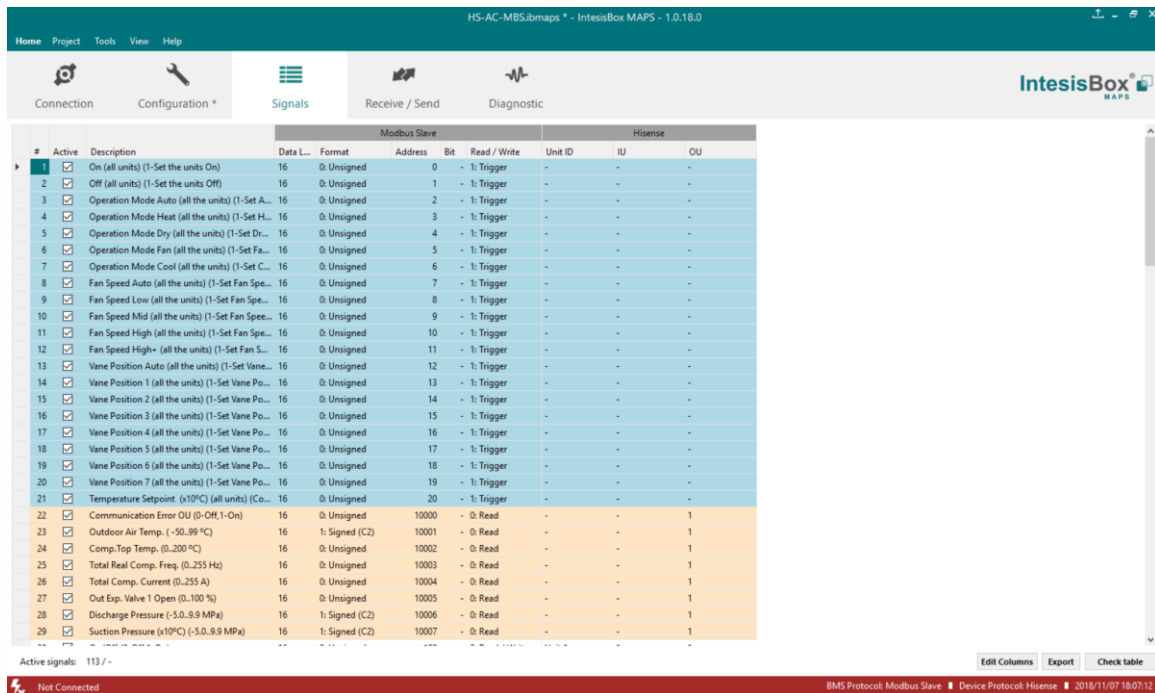

Figure 4.8 Intesis MAPS Signals tab

### 1.12.7 Sending the configuration to Intesis

When the configuration is finished, follow the next steps.

1.- Save the project (Menu option **Project->Save**) on your hard disk (more information in Intesis MAPS User Manual).

2.- Go to tab '**Receive / Send**' of MAPS, and in **Send** section, press **Send** button. Intesis will reboot automatically once the new configuration is loaded.

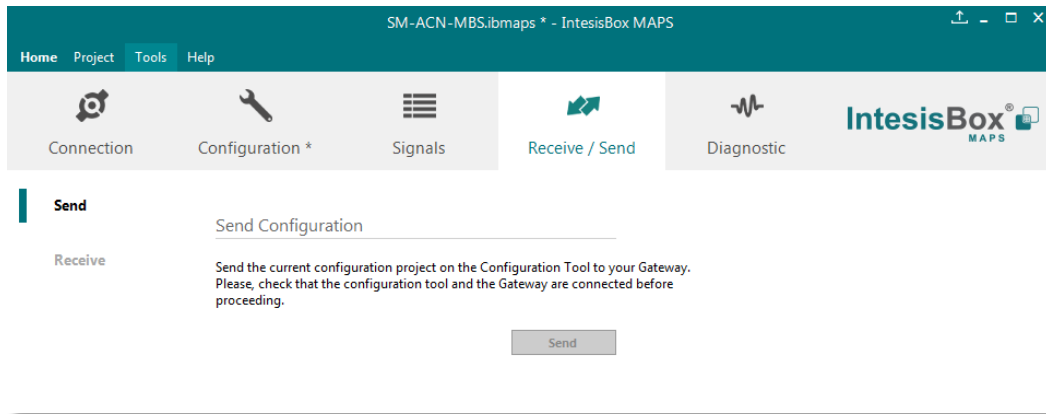

**Figure 4.9** Intesis MAPS Receive/Send tab

**After any configuration change, do not forget to send the configuration file to the Intesis using the Send button in the Receive / Send section.**

### 1.12.8 Diagnostic

To help integrators in the commissioning tasks and troubleshooting, the Configuration Tool offers some specific tools and viewers.

In order to start using the diagnostic tools, connection with the Gateway is required.

The Diagnostic section is composed by two main parts: Tools and Viewers.

- **Tools**  
Use the tools section to check the current hardware status of the box, log communications into compressed files to be sent to the support, change the Diagnostic panels' view or send commands to the gateway.
- **Viewers**  
In order to check the current status, viewer for the Internal and External protocols are available. It is also available a generic Console viewer for general information about communications and the gateway status and finally a Signals Viewer to simulate the BMS behavior or to check the current values in the system.

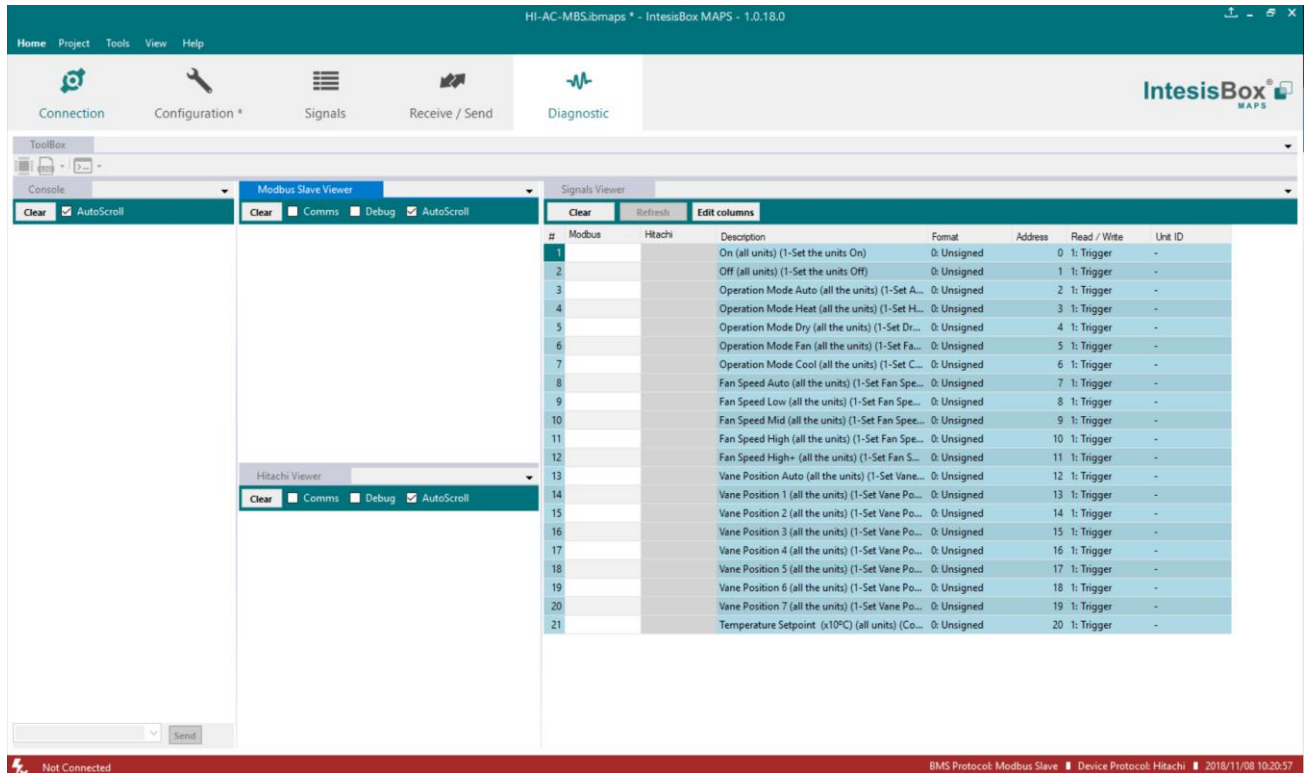

Figure 4.10 Diagnostic

More information about the Diagnostic section can be found in the Configuration Tool manual.

### 1.12.9 Set-up procedure

1. Install Intesis MAPS on your laptop, use the setup program supplied for this and follow the instructions given by the Installation wizard.
2. Install Intesis in the desired installation site. Installation can be on DIN rail or on a stable not vibrating surface (DIN rail mounted inside a metallic industrial cabinet connected to ground is recommended).
3. If using Modbus RTU, connect the communication cable coming from the EIA485 port of the Modbus RTU installation to the port marked as Port B of Intesis (More details in section 3).

If using, Modbus TCP, connect the communication cable coming from the Ethernet port of the Modbus TCP installation to the port marked as Ethernet Port of Intesis (More details in section 3).

4. Connect the communication cable coming from the Hitachi VRF installation to the port marked as Port A of Intesis (More details in section 3).
5. Power up Intesis. The supply voltage can be 9 to 36 Vdc or just 24 Vac. Take care of the polarity of the supply voltage applied.

**WARNING!** In order to avoid earth loops that can damage Intesis and/or any other equipment connected to it, we strongly recommend:

- The use of DC power supplies, floating or with the negative terminal connected to earth. **Never use a DC power supply with the positive terminal connected to earth.**
- The use of AC power supplies only if they are floating and not powering any other device.

6. If you want to connect using IP, connect the Ethernet cable from the laptop PC to the port marked as Ethernet of Intesis (More details in section 3).  
  
If you want to connect using USB, connect the USB cable from the laptop PC to the port marked as Console of Intesis (More details in section 3).
7. Open Intesis MAPS, create a new project selecting a copy of the one named **INMBSHIT---0000**.
8. Modify the configuration as desired, save it and download the configuration file to Intesis as explained in the Intesis MAPS user manual.
9. Visit the Diagnostic section, enable COMMS () and check that there is communication activity, some TX frames and some other RX frames. This means that the communication with the Centralized Controller and Modbus Master devices is OK. In case there is no communication activity between Intesis and the Centralized Controller and/or Modbus devices, check that those are operative: check the baud rate, the communication cable used to connect all devices and any other communication parameter.

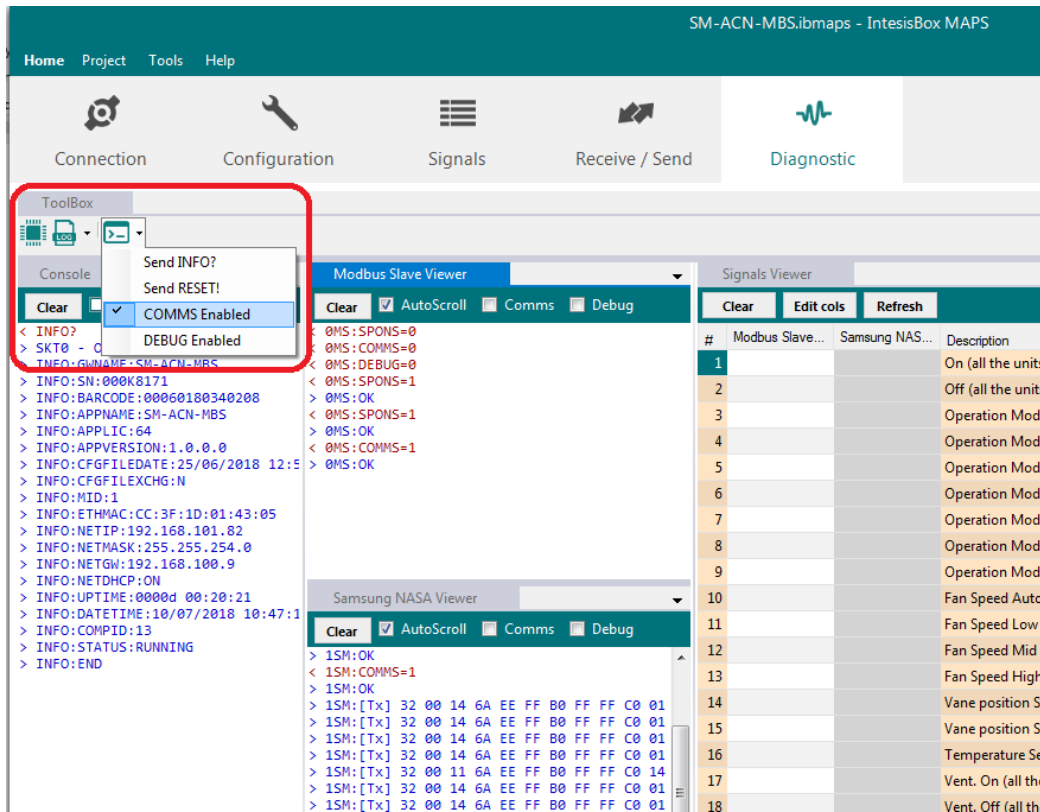

Figure 4.11 Enable COMMS

## 5. Electrical & Mechanical Features



<b>Enclosure</b>	Plastic, type PC (UL 94 V-0) Net dimensions (dxwxh): 90x88x56 mm Recommended space for installation (dxwxh): 130x100x100mm Color: Light Grey. RAL 7035
<b>Mounting</b>	Wall. DIN rail EN60715 TH35.
<b>Terminal Wiring</b> (for power supply and low-voltage signals)	Per terminal: solid wires or stranded wires (twisted or with ferrule) 1 core: 0.5mm <sup>2</sup> ... 2.5mm <sup>2</sup> 2 cores: 0.5mm <sup>2</sup> ... 1.5mm <sup>2</sup> 3 cores: not permitted If cables are more than 3.05 meters long, Class 2 cable is required.
<b>Power</b>	1 x Plug-in screw terminal block (3 poles) 9 to 36VDC +/-10%, Max.: 140mA. 24VAC +/-10% 50-60Hz, Max.: 127mA Recommended: 24VDC
<b>Ethernet</b>	1 x Ethernet 10/100 Mbps RJ45 2 x Ethernet LED: port link and activity
<b>Port A</b>	1 x H-Link Plug-in screw terminal block orange (2 poles) 1500VDC isolation from other ports 1 x Plug-in screw terminal block green (2 poles) Reserved for future use
<b>Switch A (SWA)</b>	1 x DIP-Switch for PORTA configuration: Reserved for future use (leave OFF, default)
<b>PORT B</b>	1 x Serial EIA232 (SUB-D9 male connector) Pinout from a DTE device 1500VDC isolation from other ports (except PORT B: EIA485) 1 x Serial EIA485 Plug-in screw terminal block (3 poles) A, B, SGND (Reference ground or shield) 1500VDC isolation from other ports (except PORT B: EIA232)
<b>Switch B (SWB)</b>	1 x DIP-Switch for serial EIA485 configuration: Position 1: ON: 120 Ω termination active Off: 120 Ω termination inactive (default) Position 2-3: ON: Polarization active Off: Polarization inactive (default)

<b>Battery</b>	Size: Coin 20mm x 3.2mm Capacity: 3V / 225mAh Type: Manganese Dioxide Lithium
<b>Console Port</b>	Mini Type-B USB 2.0 compliant 1500VDC isolation
<b>USB port</b>	Type-A USB 2.0 compliant Only for USB flash storage device (USB pen drive) Power consumption limited to 150mA (HDD connection not allowed)
<b>Push Button</b>	Button A: Not used Button B: Not used
<b>Operation Temperature</b>	0°C to +60°C
<b>Operational Humidity</b>	5 to 95%, no condensation
<b>Protection</b>	IP20 (IEC60529)
<b>LED Indicators</b>	10 x Onboard LED indicators 2 x Run (Power)/Error 2 x Ethernet Link/Speed 2 x Port A TX/RX 2 x Port B TX/RX 1 x Button A indicator 1 x Button B indicator

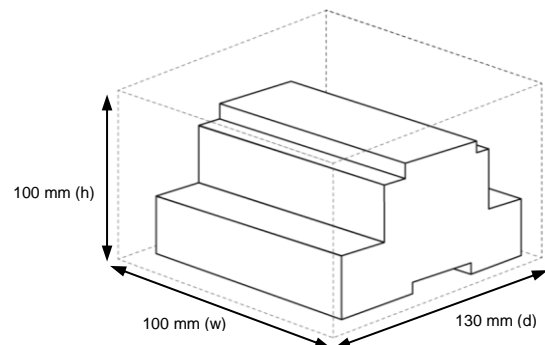



## 6. Dimensions

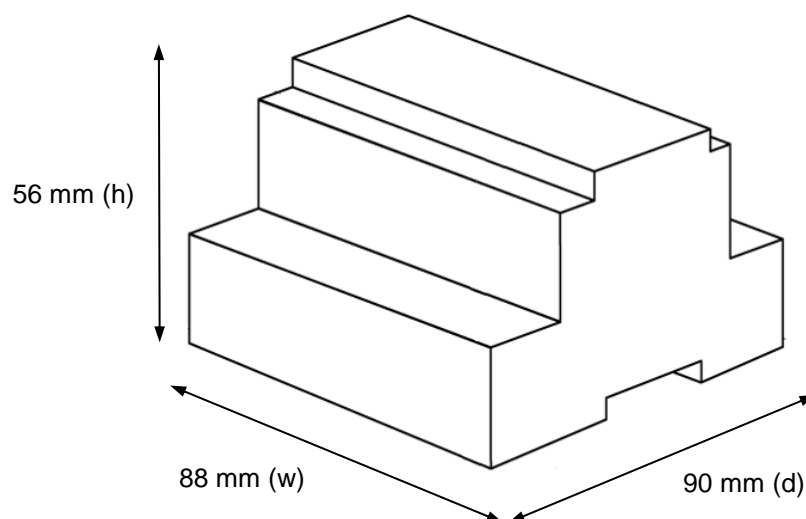

Recommended available space for its installation into a cabinet (wall or DIN rail mounting), with space enough for external connections

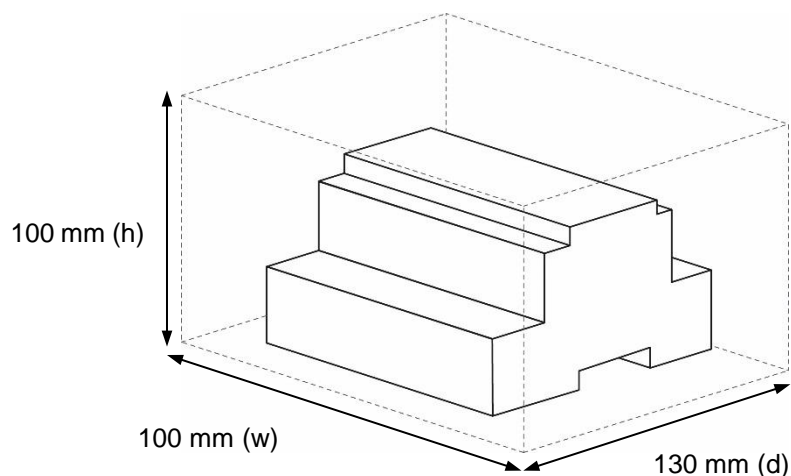

## 7. AC Unit Types compatibility

A list of Hitachi unit model references compatible with INMBSHIT---O000 and their available features can be found in:

[https://www.intesis.com/docs/compatibilities/inxxxhit001r000\\_compatibility](https://www.intesis.com/docs/compatibilities/inxxxhit001r000_compatibility)

## 8. Error codes for Indoor and Outdoor Units

This list contains all possible values shown in Modbus register for “Error Code” for each indoor unit and outdoor unit.

It must be taken into account that Outdoor Units are only able to reflect a single error for each indoor / outdoor unit in the system. Thus, a unit having two or more active errors from that list will only report a single error code – the one of the first error that has been detected.

Error Code	Category	Content of Abnormality	Leading Cause
01	Indoor Unit	Activation of Protection Device (Float Switch)	Activation of Float Switch (High Water Level in Drain Pan, Abnormality of Drain Pipe, Float Switch or Drain Pan)
02	Outdoor Unit	Activation of Protection Device (High Pressure Cut)	Activation of PSH (Pipe Clogging, Excessive Refrigerant! Inert Gas Mixing)
03	Transmission	Abnormality between Indoor and Outdoor	incorrect Wiring, Loose Terminals, Disconnect Wire, Blowout of Fuse, Outdoor Unit Power OFF
04		Abnormality between Inverter PCB and Outdoor PCB	Inverter PCB - Outdoor PCB Transmission Failure (Loose Connector, Wire Breaking, Blowout of Fuse)
04.		Abnormality between Fan Controller and Outdoor PCB	Fan Controller - Outdoor PCB Transmission Failure (Loose Connector, Wire Breaking, Blowout of Fuse)
05	Supply Phase	Abnormality Power Source Phases	Incorrect Power Source, Connection to Reversed Phase, Open-Phase
06	Voltage	Abnormal Inverter Voltage	Outdoor Voltage Drop, insufficient Power Capacity
06.		Abnormal Fan Controller Voltage	Outdoor Voltage Drop, Insufficient Power Capacity
07	Cycle	Decrease in Discharge Gas Superheat	Excessive Refrigerant! Charge, Failure of Thermistor, Incorrect Wiring, Incorrect Piping Connection, Expansion Valve Locking at Opened Position (Disconnect Connector)
08		Increase in Discharge Gas Temperature	Insufficient Refrigerant! Charge, Pipe Clogging, Failure of Thermistor, Incorrect Wiring, Incorrect Piping Connection, Expansion Valve Locking at Closed

			Position (Disconnect Connector)
0A	Transmission	Abnormality between Outdoor and Outdoor	Incorrect Wiring, Breaking Wire, Loose Terminals
0b	Outdoor Unit	Incorrect Outdoor Unit Address Setting	Duplication of Address Setting for Outdoor Units (Sub Units) in Same Refrigerant! Cycle System
0c		Incorrect Outdoor Unit Main Unit Setting	Two (or more) Outdoor Units Set as "Main Unit" Exist in Same Refrigerant! Cycle System
11	Sensor on Indoor Unit	Inlet Air Thermistor	Incorrect Wiring, Disconnecting Wiring, Breaking Wire, Short Circuit
12		Outlet Air Thermistor	
13		Freeze Protection Thermistor	
14		Gas Piping Thermistor	
19	Fan Motor	Activation of Protection Device for Indoor Fan	Fan Motor Overheat, Locking
21	Sensor on Outdoor Unit	High Pressure Sensor	Incorrect Wiring, Disconnecting Wiring, Breaking Wire, Short Circuit
22		Outdoor Air Thermistor	
23		Discharge Gas Thermistor on Top of Compressor	
24		Heat Exchanger Liquid Pipe Thermistor	
25		Heat Exchanger Gas Pipe Thermistor	
29		Low Pressure Sensor	
31	System	Incorrect Capacity Setting of Outdoor Unit and Indoor Unit	Incorrect Capacity Code Setting of Combination Excessive or Insufficient Indoor Unit Total Capacity Code
35		Incorrect Setting of Indoor Unit No.	Duplication of Indoor Unit No. in same Ref. Gr.
36		Incorrect of Indoor Unit Combination	Indoor Unit is Designed for R22
38		Abnormality of Picking up Circuit for Protection in Outdoor Unit	Failure of Protection Detecting Device (Incorrect Wiring of Outdoor PCB)
39	Compressor	Abnormality Running Current at Constant! Speed Compressor	Overcurrent, Blowout Fuse, Current Sensor Failure, instantaneous Power Failure, Voltage Drop, Abnormal Power Supply
3A	Outdoor Unit	Abnormality of Outdoor Unit Capacity	Outdoor Unit Capacity > 510kBtu/h
3b		Incorrect Setting of Outdoor Unit Models Combination or Voltage	Incorrect Setting of Main and Sub Unit(s) Combination or Voltage
		Abnormality Transmission between Main Unit and Sub Unit(s)	Incorrect Wiring, Disconnect Wire, Breaking Wire, PCB Failure

3d			
43	Protection Device	Activation of Low Compression Ratio Protection Device	Defective Compression (Failure of Compressor of Inverter, Loose Power Supply Connection)
44		Activation of Low Pressure Increase Protection Device	Overload at Cooling, High Temperature at Heating, Expansion Valve Locking (Loose Connector)
45		Activation of High Pressure Increase Protection Device	Overload Operation (Clogging, Short-Pass), Pipe Clogging, Excessive Refrigerant!, Inert Gas Mixing
47		Activation of Low Pressure Decrease Protection Device (Vacuum Operation Protection)	Insufficient Refrigerant!, Refrigerant! Piping, Clogging, Expansion Valve Locking at Open Position (Loose Connector)
48		Activation of Inverter Overcurrent Protection Device	Overload Operation, Compressor Failure
51	Sensor	Abnormal Inverter Current! Sensor	Current! Sensor Failure
53	Inverter	Inverter Error Signal Detection	Driver IC Error Signal Detection (Protection for Overcurrent, Low Voltage, Short Circuit)
54		Abnormality of Inverter Fin Temperature	Abnormal Inverter Fin Thermistor, Heat Exchanger Clogging, Fan Motor Failure
55		Inverter Failure	Inverter PCB Failure
57	Fan Controller	Activation of Fan Controller Protection	Driver IC Error Signal Detection (Protection for Overcurrent, Low Voltage, Short Circuit), Instantaneous Overcurrent
5A		Abnormality of Fan Controller Fin Temperature	Fin Thermistor Failure, Heat Exchanger Clogging, Fan Motor Failure
5b		Activation of Overcurrent Protection	Fan Motor Failure
5C		Abnormality of Fan Controller Sensor	Failure of Current! Sensor (Instantaneous Overcurrent, Increase of Fin Temperature, Low Voltage, Earth Fault, Step-Out)
EE	Compressor	Compressor Protection Alarm (It is cannot be reset from remote Controller)	This alarm code appears when the following alarms• occurs three times within 6 hours.  *02, 07, 08, 39, 43 to 45, 47
b1	Outdoor Unit No. Setting	Incorrect Setting of Unit and Refrigerant! Cycle No.	Over 64 Number is Set for Address or Refrigerant! Cycle.
	Indoor Unit No. Setting		More than 17 Non-Corresponding to Hi-NET Units are Connected to One System.

b5		Incorrect Indoor Unit Connection Number Setting	
C1	Switch Box Unit	Incorrect Indoor Unit Connection	2 or more Switch Box Units are connected between outdoor unit and indoor unit.
C2		Incorrect Indoor Unit Connection No. Setting	9 or More Indoor Units Connected to Switch Box Unit
C3		Incorrect Indoor Unit Connection	The indoor units of different refrigerant! cycle is connected to Switch Box unit.