

**Brightness Sensor UP 255/01 (for Switch / Dim Actuator N526/02)**  
**Brightness Sensor AP 255/02 (for Switch / Dim Actuator N526/02)**

**5WG1 255-4AB01**  
**5WG1 255-4AB02**

## Product and functional description



Picture 1: Brightness sensor UP 255/01 (for N 526/02)



Picture 2: Brightness sensor AP 255/02 (for N 526/02)

The brightness sensor UP 255/01 or AP 255/02 is used to measure and control the lighting in the workplace or in the room. The sensor is solely intended for connection to the switch/dim actuator N 526/02. The electronics of the brightness sensor is supplied with power via the switch/dim actuator N 526/02.

Two versions of the brightness sensor are available:

- Brightness sensor UP 255/01 for insertion in a cavity wall box or flush-type box according to DIN 49073-GB-T-M1E1 (02/90),  $\varnothing$  58 mm (standard), depth 40 mm.
- Brightness sensor AP 255/02 in a surface-mounted housing ( $\varnothing$  75 mm, depth 26 mm).

The brightness sensor is supplied in both variants, each with two white sprayed optical fibres (1 x optical fibre with an even surface for light incidence and 1 x optical fibre with a tilted surface (45°)). This can be inserted as required. Due to the variation in the optical fibres, the light detection cone of the brightness sensor can be adapted to the local needs (see Diagrams 7, 8).

## Application program

Not needed  
 (see application program description of N 526/02)

## Connection example

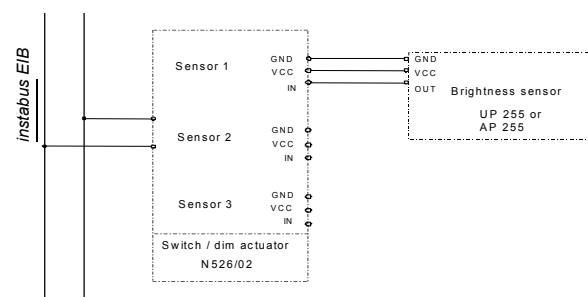

## Installation instructions

- The device may only be used for permanent interior installations in dry rooms.
- The connecting cable to the brightness sensor must be installed according to DIN VDE 0100 section 520 with a maximum length of 100 m.



## WARNING

- No cables with 230 V AC may be inserted in the flush-type box or surface-mounted box of the brightness sensor.
- Connecting the plug-in terminals to the 230 V mains voltage or to the bus cable leads to the device being damaged.
- The prevailing safety and accident regulations must be observed.
- The metal housing of the device may not be opened. Any faulty devices should be returned to the local Siemens office.

**Brightness Sensor UP 255/01 (for Switch / Dim Actuator N526/02)**  
**Brightness Sensor AP 255/02 (for Switch / Dim Actuator N526/02)**

**5WG1 255-4AB01**  
**5WG1 255-4AB02**

**Technical data**

**Measuring range**

- 0 to 1500 lux (at a 30% degree of reflection from the workplace)

**Power supply**

- The power supply (5 volts) is carried out via the switch/dim actuator N 526/02

**Connections**

- 3-pole plug-in terminal for connecting the supply and output voltage (Ø 0.6 ... 0.8 mm single-core)

**Mechanical data**

Brightness sensor UP 255/01

- Metal housing with lid (white) for installation in a cavity wall box or flush-type box according to DIN 49073-GB-T-M1E1 (02/90), Ø 58 mm (standard), depth 40 mm.

Brightness sensor AP 255/02

- Surface-mounted housing (Polypropylen, white, cable entry via openings in base of housing), Ø 75 mm, depth 26 mm, bayonet catch.

**Electrical safety**

- Degree of pollution (according to IEC 60664-1): 2
- Type of protection (according to EN 60529):
- IP 20 for UP 255/01
- IP 20 for AP 255/02
- Overvoltage category (according to IEC 60669-1): III
- Power supply: 5 volts DC via switch/dim actuator N 526/02

**EMC requirements**

- Complies with: EN 50081-1, EN 61000-6-2 and EN 50090-2-2

**Environmental conditions**

- Climatic withstand capability: EN 50090-2-2
- Ambient operating temperature: -5 ... +45 °C
- Storage temperature: -25 ... +70 °C
- Relative humidity (not condensing): 5% ... 93%

**CE mark**

- CE mark in accordance with EMC guideline [residential and functional buildings]

**Location of the plug-in terminal**

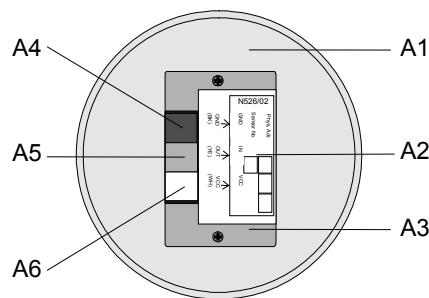

Picture 3: Location of the plug-in terminal

- B1 Underside of the cover for the flush-type box or the lid for the surface-mounted housing
- B1 Type label
- B1 Metal housing
- B1 Plug-in terminal GND
- B1 Plug-in terminal OUT for output voltage of sensor
- B1 Plug-in terminal VCC for power supply of sensor (+5 V)

**Mounting and wiring**

Brightness sensor UP 255/01

- The device is intended for insertion in a cavity wall box or flush-type box according to DIN 49073-GB-T-M1E1 (02/90), Ø 58 mm (standard), depth 40 mm.
- The brightness sensor UP 255/01 is inserted in switch boxes using the supplied screw fixing (without claws) (see Picture 4).
- The connection of the supply voltage and output voltage is carried out via a 3-pole plug-in terminal (plug-in screwless terminal for single-core conductors). The plug-in terminal is located on the back of the device.

UP-Brightness Sensor UP 255/01 (for Switch / Dim Actuator N526/02)	5WG1 255-4AB01
AP-Brightness Sensor AP 255/02 (for Switch / Dim Actuator N526/02)	5WG1 255-4AB02

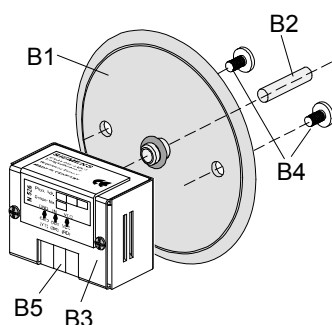

Picture 4: Installation of the brightness sensor UP 255/01

- B1 Lid with fixing holes
- B2 Optical fibre
- B3 Brightness sensor UP 255/01
- B4 Fixing screws
- B5 Plug-in terminal for sensor cable

Brightness sensor AP 255/02

- The device is supplied in a surface-mounted housing, Ø 75 mm, height 26 mm, bayonet catch (see Picture 5).
- The housing should be mounted on the ceiling above the outlet of the sensor cable.
- The connection of the supply voltage and output voltage is carried out via a 3-pole plug-in terminal (plug-in screwless terminal for single-core conductors). The plug-in terminal is located inside the surface-mounted housing on the back of the device.

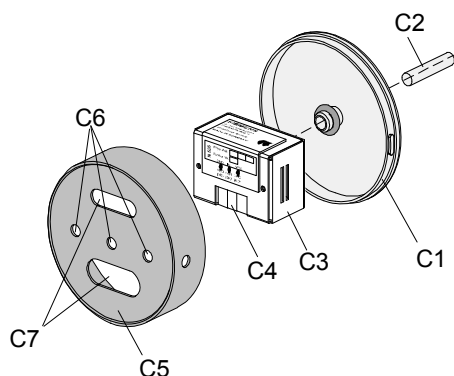

Picture 5: Installation of the brightness sensor AP 255/02

- C1 Lid with bayonet catch
- C2 Optical fibre
- C3 Brightness sensor AP 255/02
- C4 Plug-in terminal for sensor cable
- C5 Lower part of the surface-mounted housing
- C6 Fixing holes
- C7 Cable entry holes

Removing plug-in terminals (Picture 6)

- The plug-in terminal (D2) of the UP 255/01 consists of three sections (D2.1, D2.2, D2.3) and that of the AP 255/02 of one part with terminal contacts.
- Carefully insert the screwdriver in the wire entry slot in the middle section of the plug-in terminal and pull the terminal out of the metal housing.

**Note:**

Care should be taken as there is a risk of shorting the device.

Disconnecting the cable (Picture 6)

- Remove the plug-in terminal (D2) and the conductor (D2.4) from the connecting cable by rotating it backwards and forwards simultaneously.

Connecting plug-in terminals

- Place the plug-in terminal (D2) on the contact pins and press the terminal into the metal housing until it reaches the stop.

Connecting the cable (Picture 6)

- The plug-in terminal (D2) is suitable for single-core conductors with Ø 0.6... 0.8 mm.
- Strip approx. 5 mm of insulation from the conductor (D2.4) and place in the terminal (D2): black = 0 V (GND), yellow = output signal (OUT), white = +5 V (VCC).

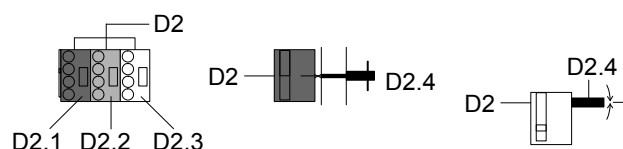

Picture 6: Connecting / disconnecting the cable

**Notes for the detection area**

- The brightness sensor should be installed above the measurement plane (work surface] e.g. at the ceiling. That optical fibre which fits best to the local lighting conditions has to be inserted into the sensors housing until the limit stop (15 mm). The sensor must be aligned vertically with the longitudinal axis of the optical fibre and point downwards.
- It must be ensured that the brightness sensor only measures indirect, reflected light. Any direct sunlight falling on the optical fibre or direct light beams from a luminaire lead to errors during measurement which impair the controller.

<b>Brightness Sensor UP 255/01 (for Switch / Dim Actuator N526/02)</b>	<b>5WG1 255-4AB01</b>
<b>Brightness Sensor AP 255/02 (for Switch / Dim Actuator N526/02)</b>	<b>5WG1 255-4AB02</b>

- A calibration of the sensor is not always required. Differences in the brightness detection may however occur depending on the degree of reflection on the surface of the equipment in the room. If there is a need for a precise measurement and control, a calibration of the sensor (see application program description of the N 526/02) should be carried out.
- When using the white sprayed optical fibre with an even surface, the detection cone indicated in Picture 7 is given.

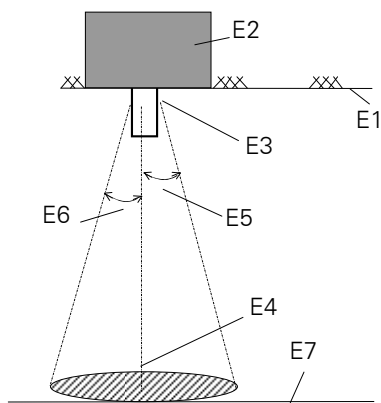

Picture 7: Detection cone of a fibre with an even surface

- E1 Ceiling
- E2 Metal housing of the sensor
- E3 Optical fibre
- E4 Longitudinal axis of optical fibre
- E5 Angle approx. 15°
- E6 Angle approx. 5°
- E7 Measurement plane (work surface)

- The white sprayed optical fibre with a tilted surface and the detection cone indicated in Picture 8 can be used to avoid or reduce the amount of light falling directly on the sensor.
- The optical fibre with a tilted surface should be aligned so that the smallest possible amount of external light falls directly on the surface:
  - If only one side of the room has windows, the long side of the optical fibre must be aligned towards the window side.
  - If there are windows on two or three sides of the room, the short (tilted) side of the optical fibre must be aligned towards a wall without any windows (if possible against the darkest wall).

- If there is glass all round the room, the short (tilted) side of the optical fibre must be aligned northwards.

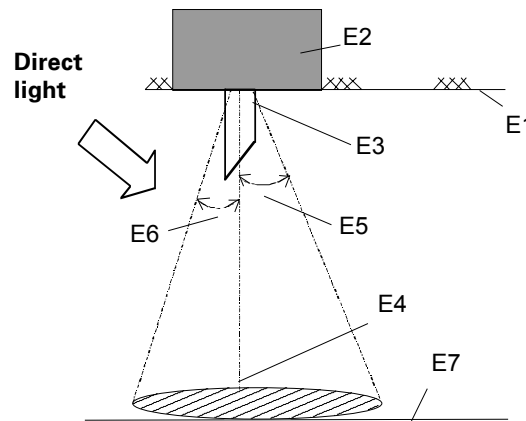

Picture 8: Detection cone of a fibre with a tilted surface

- E1 Ceiling
- E2 Metal housing of the sensor
- E3 Optical fibre
- E4 Longitudinal axis of optical fibre
- E5 Angle approx. 45°
- E6 Angle approx. 5°
- E7 Measurement plane (work surface)

**General notes**

- Any faulty devices should be returned to the local Siemens office.
- If you have further questions about the product, please contact our Technical Support:
  - +49 (0) 180 50 50-222
  - +49 (0) 180 50 50-223
  - [www.siemens.com/automation/support-request](http://www.siemens.com/automation/support-request)