

Water Detector UP 272

5WG1 272-2AB_1



Product	DELTA profil		DELTA style	
Water De-tector UP 	titanium white	5WG1 272-2AB11	titanium white	5WG1 272 2AB11
	silver	5WG1 272-2AB71		
	anthracite	5WG1 272-2AB21		
	pearl grey	5WG1 272-2AB01		
Frame	To be ordered separately from the DELTA range			
	cut-out frames			
Tier frame	—		titanium white	5TG1 1328
Bus coupling unit	UP 110; UP 114; UP 115			

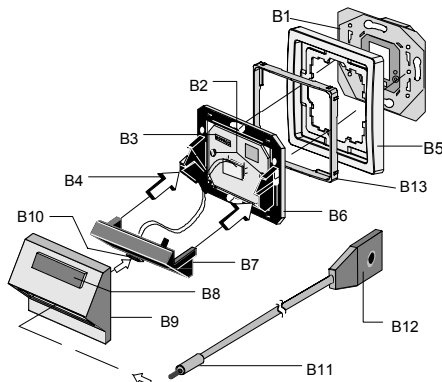

Diagram 1: Water detector UP

- B1 bus coupling unit UP
- B2 mounting screws basic module *)
- B3 6 pin bar *)
- B4 6 pin plug-in connector with socket bar *)
- B5 frame
- B6 basic module *)
- B7 supporting plate *)
- B8 note label *)
- B9 cover *)
- B10 pawl socket *)
- B11 pawl plug *)
- B12 sensor body *)
- B13 tier frame

*) Scope of supply

Product and Applications Description

The water detector is destined to detect floor water in residential buildings. It consists of a flush mounted device to be plugged upon a water sensor which can be mounted near the ground.

The water detector is connected with a 2 meter terminal line and is connected with the flush mounted device of the water detector via a pawl plug. The terminal line can be prolonged up to 20 meters.

The detection of water is realised via two electrodes on the water sensor. If both electrodes have a conductive connection with water a warning alarm is sparked off according the parameter settings in the application program.

The flush mounted device of the water detector is stuck upon the bus coupling unit UP (from version 1.2 onward) together with the matching frame and works only in connection with the bus coupling unit UP, i.e. the water detector (with bus coupling unit UP) consists of the device (hardware) and the application program (software).

The bus coupling unit UP and its frame are not included in the volume of delivery and must be ordered separately. For DELTA style a tier frame is required.

Application programs

12 S1 Water Detector 211701

- water alarm
- water alarm is continued until being acknowledged and no water is detected
- allows reporting broken wires

Example of Operation



Installation Instructions

- The device may be used for permanent interior installations in dry locations within box mounts (in combination with a bus coupling unit UP).
- The water detector can be used for permanent indoor mountings



WARNING

- The device must be mounted and commissioned by an authorised electrician.
- The device must not be installed in box mounts together with 230 V devices.
- The device may be mounted to switch and socket combination box mounts (in combination with a bus coupling unit UP) if VDE-certified devices are used and the mounting hanger is earthed exclusively.
- The water detector must not be deposited or mounted near a 230 V area.
- Due to the pulsating electric field when dipped in water the device is not suitable for use in aquariums.
- The water detector is not suitable for use in acid solutions.
- For planning and construction of electric installations, the relevant guidelines, regulations and standards of the respective country are to be considered.

Technical data

The specifications apply for the flush mounted device and the water detector as far as there is no different specification

Power supply

- flush mounted device: is realised via the bus coupling unit UP
- water detector: is realised via the flush mounted device pulsing voltage max. 30 Vs, short circuit proof.

Connections

- flush mounted device:
 - 10 pin bar (PEI) for connection to the bus coupling unit (UP)
 - terminal socket for the pawl plug Ø 2,5 mm for connecting the water detector
- water detector:
 - 2 meter terminal line permanently connected with the water detector with pawl plug Ø 2,5 mm. The terminal line can be prolonged up to max. 20 m, not depending on the polarisation

Water Detector 272

5WG1 272-2AB_1

Physical specifications

- flush mounted device:
 - housing: plastic
 - dimensions (L x W x D):
65 x 65 x 40 mm
 - weight: approx. 60 g
 - fire load: approx. 1450 kJ ± 10 %
 - installation: slide onto bus coupling unit and secure with mounting screws included
- water detector
 - insulation: plastic
 - length: 2000 mm
 - weight: approx. 45 g incl. wire and pawl plug
 - mounting (optional): near the ground

Electrical safety

- degree of pollution (according to IEC 60664-1): 2
- protection (according to IEC 529):
 - water detector: IP 20
 - water sensor: IP 64
- protection class (according to IEC 61140-1): III
- overvoltage class (according to IEC 60664-1): III
- bus: safety extra low voltage SELV DC 24 V
- device complies with
EN 5090-2-2 and IEC 60664-1: 1992

Reliability

rate of failure: 84 fit at 40 °C

Electromagnetic compatibility

complies with EN 50081-1, EN 61 000-6-2 and EN 50090-2-2

Environmental specifications

- climatic conditions: EN 50090-2-2
- ambient temperature operating: - 5 ... + 45 °C
- ambient temperature non-op.: - 25 ... + 70 °C
- relative humidity (non-condensing): 5 % to 93 %

Certification

EIB certificate

CE norm

complies with the EMC regulations (residential and functional buildings), and low voltage regulations

Location and function of the operating elements

Diagram 2: basic module and supporting plate

- A1 6 pin bar
- A2 mounting screws
- A3 6 pin plug-in connector with socket bar
- A4 pawl socket Ø 2,5 mm

Notes for Configuration

The configuration of the water detector happens during down-loading the application program. Therefore the sensor has to be connected with its genuine terminal line and must be dry.

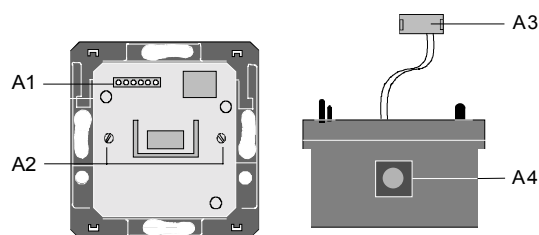
Mounting

The flush mounted device of the water detector is stuck upon the matching onto the bus coupling unit (UP)

- The UP bus coupling unit is mounted into a flush-mount box (see installation instruction of the UP bus coupling unit).

Sequence of assembly

- The basic module (B6) is stuck upon the bus coupling unit UP (B1) together with the frames (B5/B13).
- Drive the mounting screw (B2) into (B1).
- Stick the supporting plate (B7) onto the basic module (B6) and insert the 6-pole wire into (B3)
- Snap on the cover (B9).
- The cover of the note label (B8) can be removed by meshing into the recesses on its side faces if a note shall be applied.
- The pawl plug (B11) of the water detector has to be plugged into the pawl socket (B10) of the cover.
- The body of the sensor (B12) can be fixed near the ground with a countersunk screw M3.

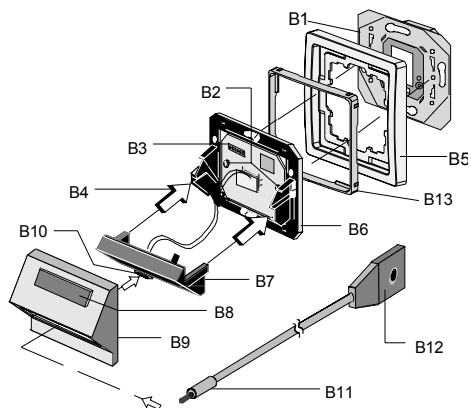

Diagram 2: mounting the flush mounted device with water detector

- B1 bus coupling unit UP
- B2 mounting screws basic module
- B3 6 pin bar
- B4 6 pin plug-in connector with socket bar
- B5 frame
- B6 basic module
- B7 supporting plate
- B8 lettering label
- B9 cover
- B10 pawl socket
- B11 pawl plug
- B12 sensor body
- B13 tier frame

Dismounting

- Remove pawl plug (B11) from (B10).
- Seize the cover (B9) on both sides and remove it by sliding it upwards.
- Loosen the screws (B2) and remove (B6) from (B1).

Dimension Diagram

Dimensions in mm

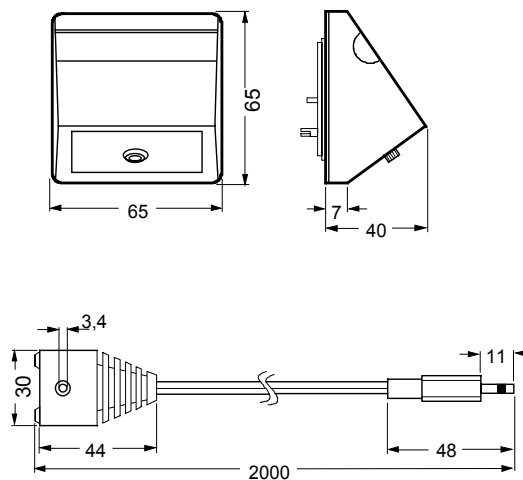

General Notes

- Any faulty devices should be returned to the local Siemens office.
- If you have further questions about the product, please contact our Technical Support:

☎ +49 (0) 180 50 50-222
 ☎ +49 (0) 180 50 50-223
 ✉ adssupport@siemens.com