

Shutter Switch UP 520/01
 1 x 230 V AC / 6 A

5WG1 520-2AB01

Product and Applications Description



The shutter switch UP 520/01 is a switching actor with additional physical external interface for mounting flush-mounting boxes. It can raise or lower a blind drive and turn the louvres open or closed gradually by its-volt free contacts. The shutter switch is mounted in mounting-boxes (60mm Ø, 60mm depth). EIB detection modules (e.g. push buttons) can be plugged onto the 10 pin physical external interface. The shutter switch is connected with the EIB bus via screwless plug-in connection blocks.

One channel is available for the connection of one shutter actuator. Each of the volt-free contacts (two bi-stable relays) can be assigned various tasks depending on the application program used, i.e. the shutter switch UP 520/01 consists of the device (hardware) and its application programs (software).

With the ETS (*EIB Tool Software*) the application program is selected, its parameters and addresses are assigned appropriately, and downloaded to the shutter switch UP 520/01.

Application Programs

The application programs of the shutter switch UP 520/01 always consist of the actuating program element and the sensor program element. The tasks of the actuating program element in the application programs are identical, only the sensor program elements are different.

The tasks of the actuating program element are:

- single blinds control with safety mode
- allows controlling blinds/shutters
- reverse delay
- characteristic in case of bus voltage failure can be set in parameter list

20 A1 Actuator - BCU - Shu, 902002

- sensor element
 - allows switching, shutter control or dimming
 - allows activating and programming scenes
 - each rocker press point allows an 8 bit value to be transmitted
 - LEDs permanently off or available as state display or as orientation light

20 A1 Actuator - BCU - Shu, single profil 902402

- sensor element
 - single push button
 - allows switching, shutter control or dimming
 - allows activating and programming scenes
 - each rocker press point allows an 8 bit value to be transmitted
 - LEDs permanently off or available as state display or as orientation light

20 A1 Actuator - BCU - Shu, double profil 902502

- sensor element
 - double push button
 - allows switching, shutter control or dimming
 - allows activating and programming scenes
 - each rocker press point allows an 8 bit value to be transmitted
 - LEDs permanently off or available as state display or as orientation light

20 A1 Actuator - BCU - Shu, 4-fold profil 902602

- sensor element
 - 4-fold push button
 - allows switching, shutter control or dimming
 - allows activating and programming scenes
 - each rocker press point allows an 8 bit value to be transmitted
 - LEDs permanently off or available as state display or as orientation light

20 A1 Actuator - BCU - Shu, 4-fold profil 902802

- sensor element
 - 4-fold push button
 - allows switching, shutter control or dimming
 - allows activating and programming scenes
 - each rocker press point allows an 8 bit value to be transmitted

Shutter Switch UP 520/01
1 x 230 V AC / 6 A

5WG1 520-2AB01

- LEDs permanently off or available as state display or as orientation light

20 A1 Actuator - BCU - Shu, single fold profil 902902

- sensor element
 - 1-fold push button
 - allows switching, shutter control or dimming
 - allows activating and programming scenes
 - each rocker press point allows an 8 bit value to be transmitted
 - orientation light always off or on

20 A1 Actuator - BCU - Shu, 2-fold profil 902A02

- sensor element
 - 2-fold push button
 - allows switching, shutter control or dimming
 - allows activating and programming scenes
 - each rocker press point allows an 8 bit value to be transmitted
 - orientation light always off or on

20 A1 Actuator - BCU - Shu, single fold profil 902C02

- sensor element
 - 1-fold push button
 - allows switching, shutter control or dimming
 - allows activating and programming scenes
 - each rocker press point allows an 8 bit value to be transmitted
 - LEDs permanently off or available as state display or as orientation light

20 A1 Actuator - BCU - Shu, 2-fold profil 902D02

- sensor element
 - 2-fold push button
 - allows switching, shutter control or dimming
 - allows activating and programming scenes
 - each rocker press point allows an 8 bit value to be transmitted
 - LEDs permanently off or available as state display or as orientation light

WARNING

If the shutter switch UP 520/01 is used for shutter drives take care of the following (otherwise the contacts may be welded):

- The factor and base values of the parameter "reverse delay" must be combined to establish a time period as given by the blinds manufacturer (usually > 500 ms).
- The parameter "on bus voltage failure" should be set to "maintain actual state" or "stop".

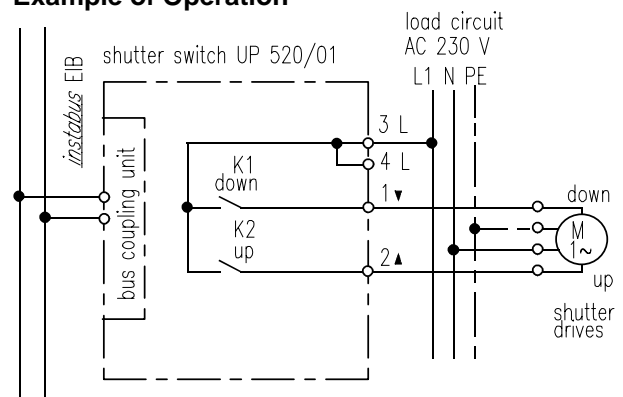
Example of Operation

Installation Instructions

- The device may be used for permanent interior installations in dry locations within distribution boards.

WARNING

- The device may be built into distribution boards (230/400V) together only with appropriate VDE-devices and must be mounted and commissioned by an authorised electrician.
- A safety disconnection of the device must be possible. Especially if the device is connected to different phases.
- The device may be mounted to switch and socket combination box mounts provided VDE-certified devices are used exclusively
- The prevailing safety rules must be heeded.
- The device must not be opened. A device suspected faulty should be returned to the local Siemens office.

Shutter Switch UP 520/01
1 x 230 V AC / 6 A

5WG1 520-2AB01

Technical Specifications

Power supply

via bus line

Outputs

- number: 1 output channel (volt-free contacts)
- rated voltage: AC 230 V, 47 ... 63 Hz
- rated current: 6 A resistive load
- switching current at AC 230 V:
 - 0,01 ... 6 A resistive load
 - tubular motors with auxiliary phase capacitor $\leq 14 \mu\text{F}$, max. power 500 VA at 20000 load switching cycles (UP-DOWN-STOP) respectively max. 750 VA at 12000 load switching cycles
 - total maximum load at $\cos\varphi = 0,4$; 750 VA
- switching current at DC 24 V:
 - 6 A resistive load,
 - 4 A inductive load (L/R = 7 ms)
- switching characteristic:
 - set in parameter list according to application program
- switching repetition interval: min 150 ms

Control elements

1 learning button:
for switching between normal operating mode and addressing mode

Display elements

1 red LED:
for monitoring bus voltage and displaying mode, selected with the learning button

Connections

- load circuit, physical:
 - strip insulation for 9 ... 10 mm
 - permissible conductor types/cross sections:
 - 0,5 ... 2,5 mm² single core or flexible conductor, 8 mm ultrasonically compacted
 - 0,5 ... 2,5 mm² flexible conductor with terminal pin, crimped on gas tight
 - 0,5 ... 1,5 mm² flexible conductor with connector sleeve
 - 1,0 and 1,5 mm² plain flexible conductor
- load circuit, electrical:
 - plain flexible conductor, min. 1 mm²: current carrying capacity max. 6 A
 - all other conductors, min. 1,5 mm²: current carrying capacity max. 10 A



WARNING

When looping through the L-conductor (connection blocks 3 and 4), take care that the maximum connection current of 16 A (as governed by the maximum permissible printed conductor load) is not exceeded!

- bus line: bus connection block screwless 0,6...0,8 mm Ø single core
- PEI-socket: 10 pins

Physical specifications

- housing: plastic
- dimensions:
 - spacing dimensions: 71 x 71 mm
 - mounting depth: 39 mm
- weight: approx. 80 g (incl. mounting hanger)
- fire load: approx. 991 kJ \pm 10 %
- installation: in box mounts Ø 60, 60 deep

Electrical safety

- fouling class (according to IEC 664-1): 2
- protection (according to EN 60529): IP 20
- overvoltage class (according to IEC 664-1): III
- bus: safety extra low voltage SELV DC 24 V
- relay with μ -contact
- the device complies with EN 50090-2-2 and EN 60669-2-1

Reliability

- 20000 switching cycles per contact

Electromagnetic compatibility

complies with
EN 50081-1, EN 50082-2 and EN 50090-2-2

Environmental specifications

- climatic conditions: EN 50090-2-2
- ambient temperature operating: - 5 ... + 45 °C
- ambient temperature non-op.: - 25 ... + 70 °C
- relative humidity (non-condensing): 5 % to 93 %

Certification

EIB certificate

CE norm

complies with the EMC regulations (residential and functional buildings), and low voltage regulations

Shutter Switch UP 520/01 1 x 230 V AC / 6 A	5WG1 520-2AB01
---	-----------------------

Location and Function of the Display and Operator Elements

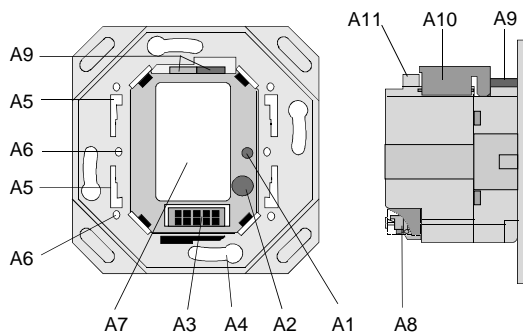

Figure 1: Location of the display and operator elements

- A1 LED for indicating normal operating mode (LED off) and addressing mode (LED on); upon receiving the physical address the device automatically returns to normal operating mode
- A2 Learning button for switching between normal operating mode and addressing mode for receiving the physical address
- A3 Physical external interface (PEI) to connect application units
- A4 Long slots to attach the application unit to the box mount
- A5 Slots to attach the application unit by guidance and fixing clamps
- A6 Thread for mounting screws (for additional fastening of the application unit e.g. as a theft protection),
- A7 Type plate
- A8 Screwless plug-in connection blocks with measuring tap to connect the load circuits
- A9 Bus connection block for single core conductors with Ø0,6...0,8 mm
- A10 Snap-on cover for bus line and single bus wires
- A11 Clamping slots for guiding the bus lines

Mounting and Wiring

The shutter switch UP 520/01 is built into box mounts (Ø 60 mm, depth 60 mm) via a screw mount. It is connected to the bus line via the bus terminal block 193 (plugged-in terminal blocks without screws for single core conductors). The application units (e.g. push buttons) are slipped onto the binary output via guiding and fastening springs and, depending on the type, tightened by screws.

Note

The shutter switch UP 520/01 must be mounted placing the physical external interface (PEI) at the bottom (figure 4) ensuring that the application units designated to be plugged on the PEI are mounted in the correct operational position. To guarantee a permanently ensured contact it is recommended to use only application units with mounting screws.

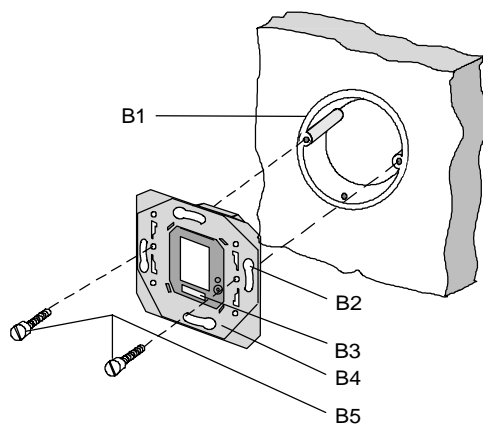

Figure 2: Mounting the shutter switch UP 520/01

- B1 Box mount (60 mm Ø according to DIN 49073)
- B2 Long slots for fastening
- B3 Physical external interface (PEI)
- B4 Shutter switch UP 520/01
- B5 Mounting screws

Shutter Switch UP 520/01
1 x 230 V AC / 6 A

5WG1 520-2AB01

Slipping off / on bus connection blocks (figure 3)

- The bus connection block (C2) is situated at the top of the shutter switch UP 520/01 (C3).
- It consists of two components (C2.1 and C2.2) with four terminal contacts each. Take care not to damage the two test sockets (C2.3) by accidentally connecting them to the bus cable or with the screw-driver (e.g. when attempting to unplug the bus connection block).

Slipping off bus connection blocks (figure 3)

- introduce the screw-driver between the cover (C1) and the binary output (C3) and lever out the cover
- Carefully put the screw-driver to the wire-inserting slit of the bus connection block's grey component (C2.2) and pull the bus connection block (C2) from the binary output (C1).

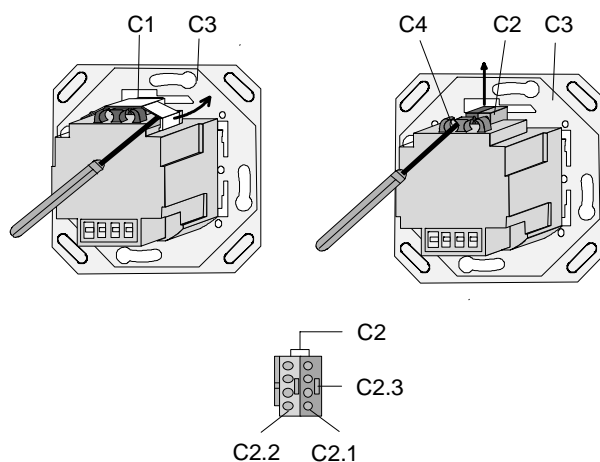

Figure 3: slipping off/on bus block

Note

Don't try to remove the bus connection block from the bottom side! There is a risk of shorting-out the device.

Connecting bus cables (figure 4)

- The bus connection block (D2) can be used with single core conductors 0,6 ... 0,8 mm Ø.
- Remove approx. 25 -35 mm of the insulation
- Remove the end of the insulation of the conductor (D2.4) and plug the last one into the connection block (D2) (red = +, grey = -).

Slipping on bus connection blocks (figure 3)

- Slip the bus connection block (C2) onto the guide slot of the binary output and
- press the bus connection block (C2) down to the stop.
- press the sheathing of the cut-off insulation bus line (figure 4) projecting >3mm into the open clamping slot (C4). If a further bus line shall be connected break out the closed clamping slot with a screw-driver and press it into the clamping slot as described above. Press the single bus wires into the recess below the bus terminal block and snap on the cover (C1).

Disconnecting bus cables (figure 4)

- Unplug the bus connection block (D2) and remove the bus cable conductor (D2.4) while simultaneously wiggling it.

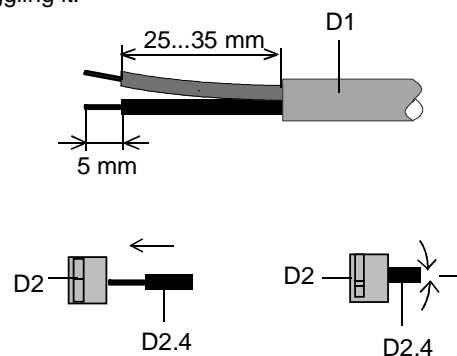

Figure 4: Connecting/disconnecting bus cables

Connecting load circuits (Figure 5)

- The load circuit is connected to screwless plug-in terminals (E1).
- Remove approx. 9 to 10 mm of insulation from the wire (E1.1) and plug it into the terminal (E1).

Conductor cross sections:

- load circuit, physical:
 - strip insulation for 9 ... 10 mm
 - permissible conductor types/cross sections:
 - 0,5 ... 2,5 mm² single core or flexible conductor, 8 mm ultrasonically compacted
 - 0,5 ... 2,5 mm² flexible conductor with terminal pin, crimped on gas tight
 - 0,5 ... 1,5 mm² flexible conductor with connector sleeve
 - 1,0 and 1,5 mm² plain flexible conductor
- load circuit, electrical:
 - plain flexible conductor, min. 1 mm²: current carrying capacity max. 6 A
 - all other conductors, min. 1,5 mm²: current carrying capacity max. 10 A

Disconnecting load circuits (Figure 5)

- Press the screw-driver onto the locking bar (F1.2) of the terminal block (F) and
- Slip the conductor (F1.1) out of the terminal block (F1)

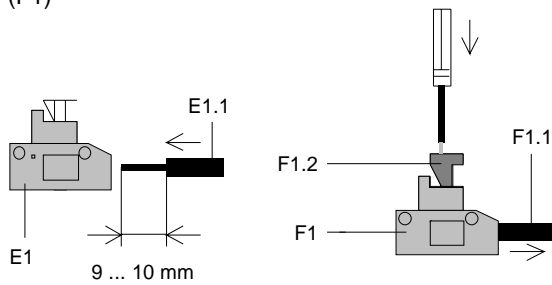

Figure 5: Connecting/disconnecting cables

Notes

Dimension Diagram

Dimensions in mm

